

LEADER IN BAGGING EQUIPMENTS



Technipes

LC 21

LC 21

■ Linea peso netto per sacchi kg 10-50.  
Sacchi carta/raffia polipropilenica/PE  
■ Produzioni fino a 600 s/h. Prodotti  
granulari/sfarinati.

■ Net weigh line for 10-50 kg bags.  
Paper bags/woven PP/poly bags.  
■ Output up to 600 bags/h. Granulated/  
powdered products.

■ Ligne de pesage-ensachage à pesées  
nettes 10/50 kg. Sacs papier/  
polypropylène/PE.  
■ Cadence jusqu'à 600 sacs/heure.  
Produits granuleux/poudre.

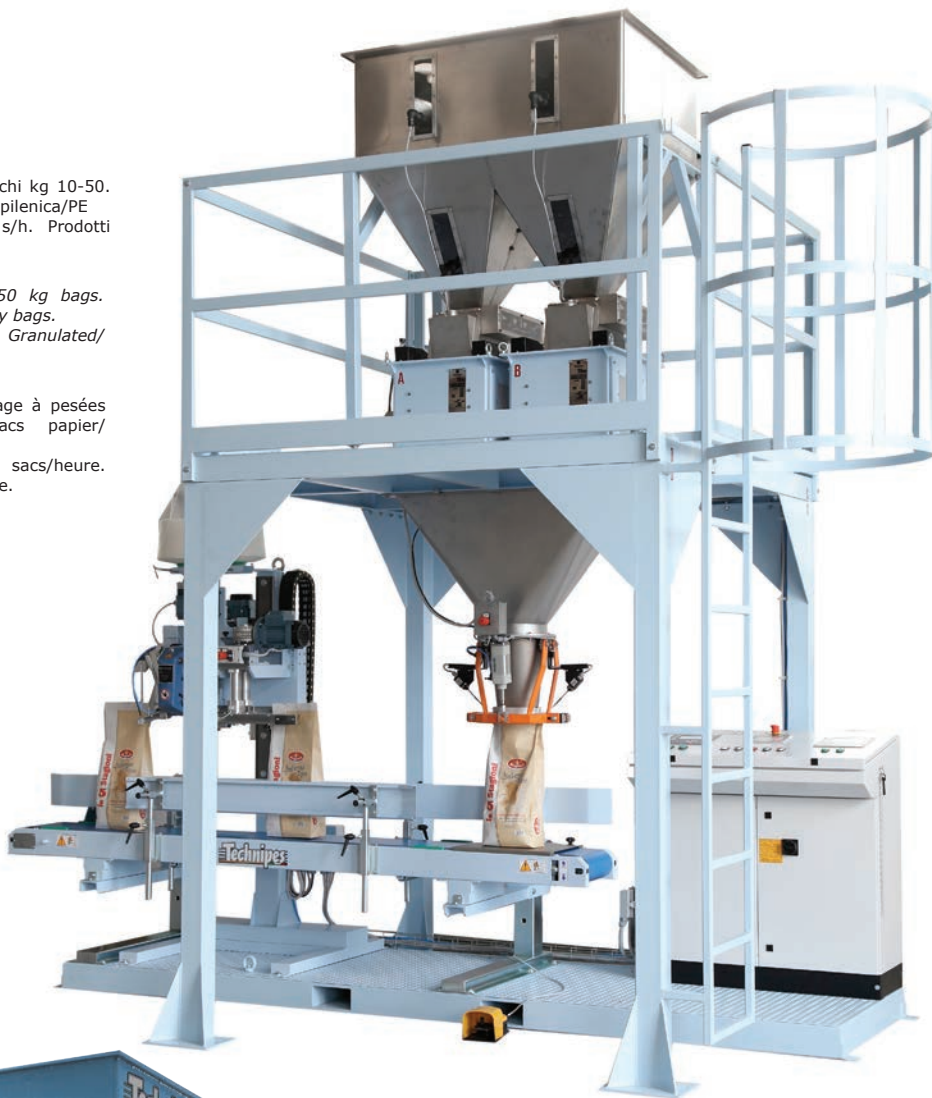

■ Linea peso netto per sacchi kg 10-50.  
Sacchi carta/raffia polipropilenica/PE  
■ Produzioni fino a 600 s/h. Prodotti  
granulari/sfarinati.

■ Net weigh line for 10-50 kg bags.  
Paper bags/woven PP/poly bags.  
■ Output up to 600 bags/h. Granulated/  
powdered products.

■ Ligne de pesage-ensachage à pesées  
nettes 10/50 kg. Sacs papier/  
polypropylène/PE.  
■ Cadence jusqu'à 600 sacs/heure.  
Produits granuleux/poudre.

Technipes

■ Linea peso lordo per sacchi kg 10-50. Sacchi carta/PE.  
■ Basse/medie produzioni fino 180-200 s/h.  
■ Prodotti granulari.

■ Gross weigh line for 10-50 kg bags. Paper/woven PP/  
poly bags. Low/medium outputs up to 180-200 bags/h.  
■ Granulated products.

■ Ligne de pesage-ensachage à pesées brutes 10/50 kg.  
■ Sacs papier/PE, petites et moyennes cadences 180-200  
sacs/heure.  
■ Produits granuleux.



## LC21 Conv-100

Linea di cucitura con convogliatore cimosa del sacco a catena e testa di cucitura tipo industriale mod. 100. Nell'immagine è presente il gruppo di ribaltamento sacco in linea a mezzo pinza, opzionale. Adatta a medie e alte produzioni.

*Sewing line with synchronized bag top chain conveyor and industrial sewing head mod. 100. Image shows the optional bag turner to lay bags flat upon exiting the sewing unit. Suitable for medium and high outputs.*

Système de couture automatique équipée d'une tête de couture modèle 100 et entraîneur pour moyennes et grandes cadences. Retourneur de sacs en ligne fond en avant.



## LC21 Conv-Rif-PG

Linea di cucitura con convogliatore cimosa del sacco a catena, gruppo di rifilatura e gruppo piega sacco in continuo. Adatta a medie e alte produzioni.

*Sewing line with synchronized bag top chain conveyor, bag top trimmer, and bag fold helix. Suitable for medium and high outputs.*

Système de couture automatique entraîneur, arasage et repliage du haut du sac pour moyennes et grandes cadences.

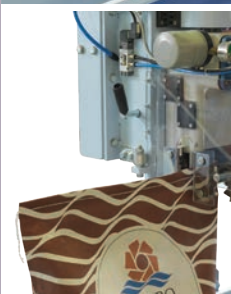
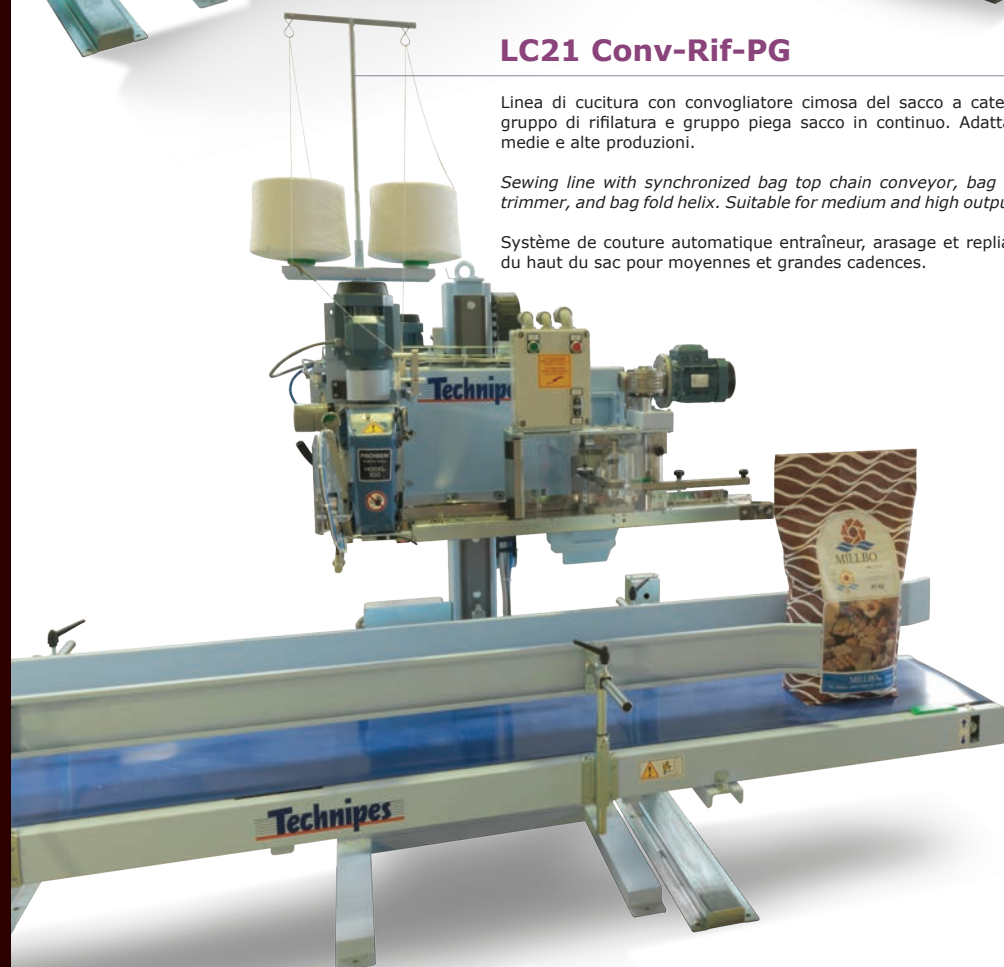

## LC21 100

Linea di cucitura con testa tipo industriale mod.100 adatta per elevate produzioni e per la cucitura di qualsiasi tipo di sacco.

*Sewing line with industrial sewing head mod.100, suitable for high outputs and sewing of any type of bag.*

Systeme de couture grande cadence équipé d'une tête de couture modèle 100. Fermeture par couture de tous types de sacs.

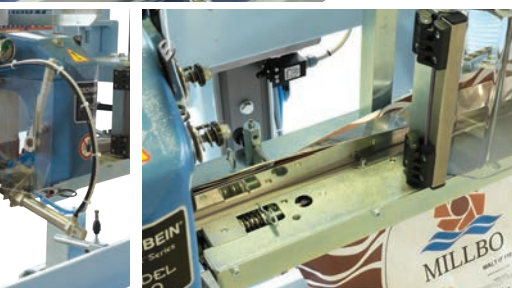
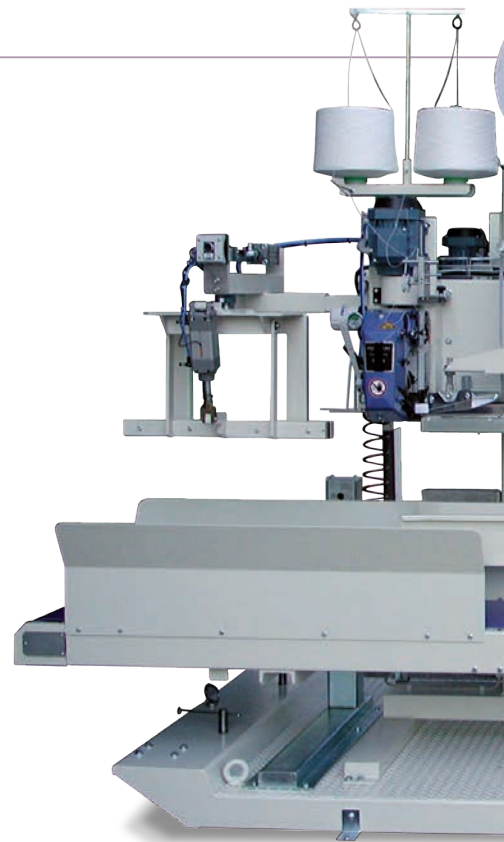

## LC21 100 DT

Linea di cucitura con due teste di cucitura tipo industriale mod.100 adatta per elevate produzioni e per la cucitura di qualsiasi tipo di sacco.

*Sewing line with dual industrial sewing heads mod. 100, designed for high outputs and sewing of any type of bag.*

Systeme de couture automatique à deux têtes de couture modèle 100 grandes cadences adapté à la fermeture de tous types de sacs.

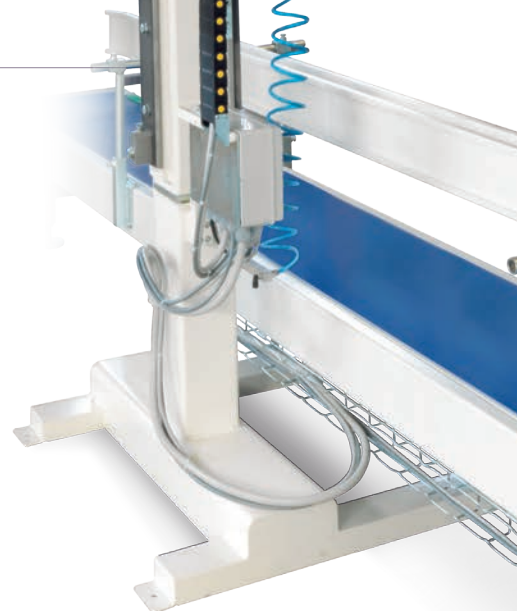

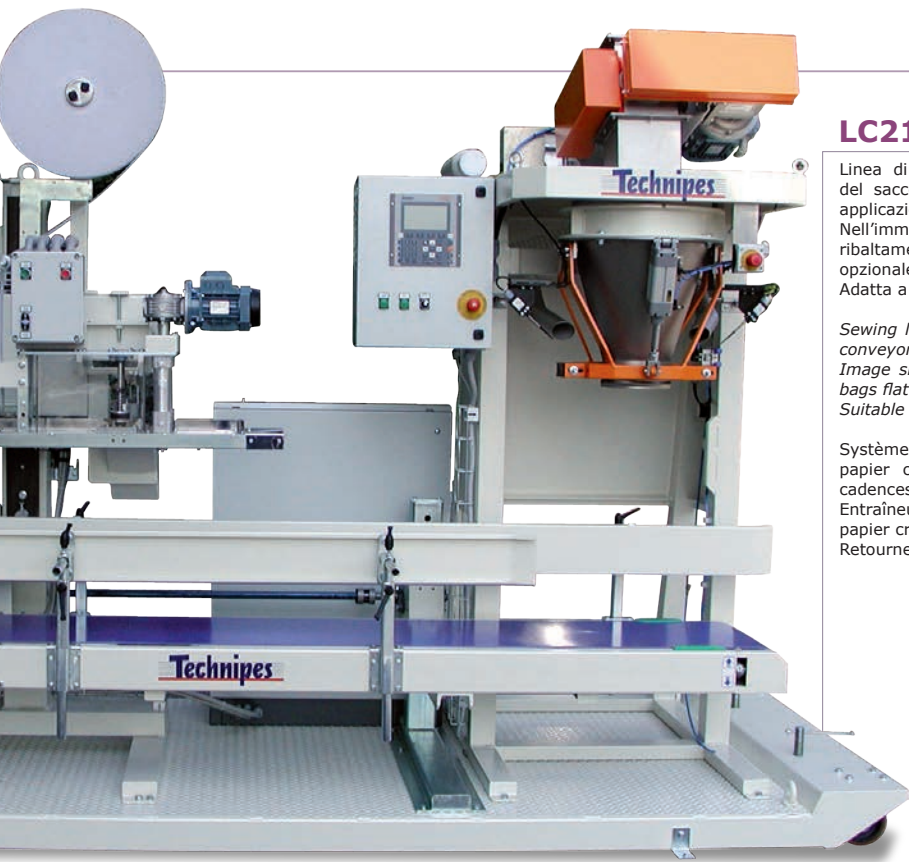

## LC21 Conv-Rif-CC

Linea di cucitura con convogliatore cimosa del sacco a catena, gruppo di rifilatura ed applicazione carta crespada a cavagliere. Nell'immagine è presente il gruppo di ribaltamento sacco in linea a mezzo pinza opzionale.

Adatta a medio-alte produzioni.

*Sewing line with synchronized bag top chain conveyor and crepe tape application assembly. Image shows the optional bag turner to lay bags flat upon exiting the sewing unit. Suitable for medium and high outputs.*

Système de couture automatique, dépose papier crépon pour moyennes et grandes cadences.

Entraîneur et arasage du haut du sac, dépose papier crépon.

Retourneur de sacs en ligne fond en avant.



## LS Conv

Linea di saldatura con convogliatore e termosaldatura in continuo per sacchi in polietilene o termo plastici in genere. Adatta a medie produzioni.

*Sealing line with heat sealer and synchronized bag top chain conveyor, for polyethylene or thermoplastic bags. Suitable for medium outputs.*

Soudeuse en continu et convoyeur pour sacs polyéthylène et thermoplastique. Moyennes cadences.

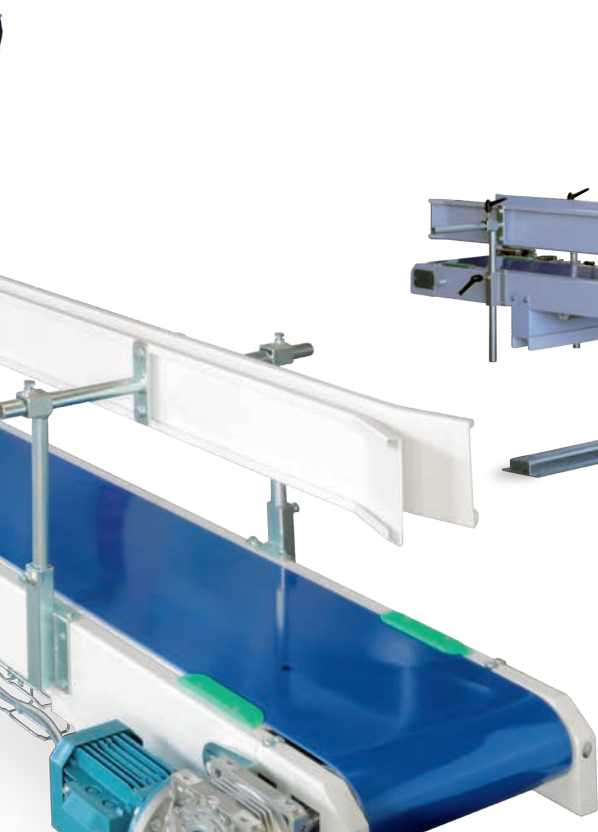

### LC21 Conv-ECR

Linea di cucitura con convogliatore cimosa del sacco a catena e testa di cucitura tipo economico mod. ECR. Adatta per basse-medie produzioni.

*Sewing line with synchronized bag top chain conveyor and economical sewing head mod. ECR. Suitable for low-medium outputs.*

Mini-système de couture équipé d'une tête de couture modèle ECR et entraîneur pour petites et moyennes cadences.

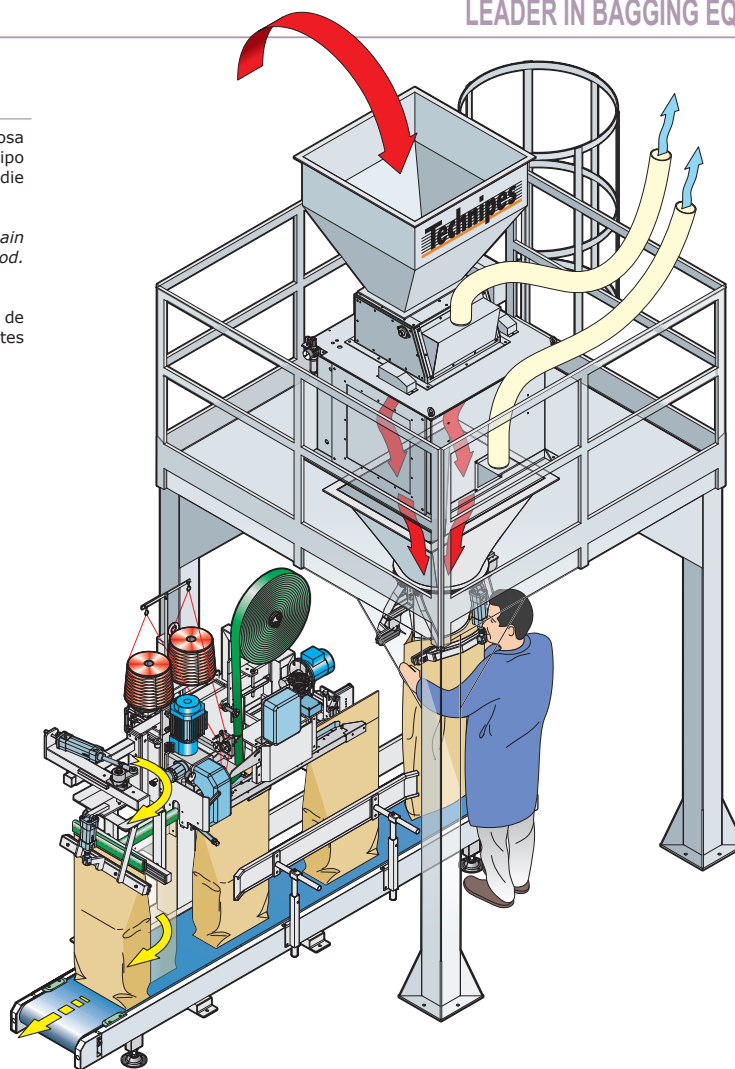
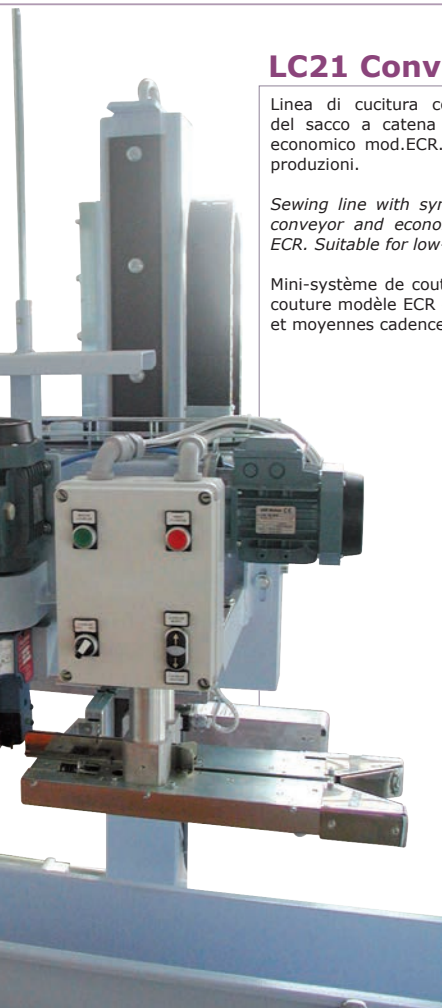

### LC21 Conv-Cart

Linea di cucitura con convogliatore cimosa del sacco a catena, gruppo applicazione cartellino prefabbricato e testa di cucitura Mod.100. Adatta a medie e alte produzioni.

*Sewing line with synchronized bag top chain conveyor, premade tag application device and industrial sewing head mod.100. Suitable for medium and high outputs.*

Système de couture automatique équipé d'une tête de couture modèle 100 et entraîneur pour moyennes et grandes cadences. Etiqueteuse automatique pour dépose d'étiquettes cartonnées prédécoupées.

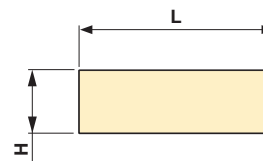
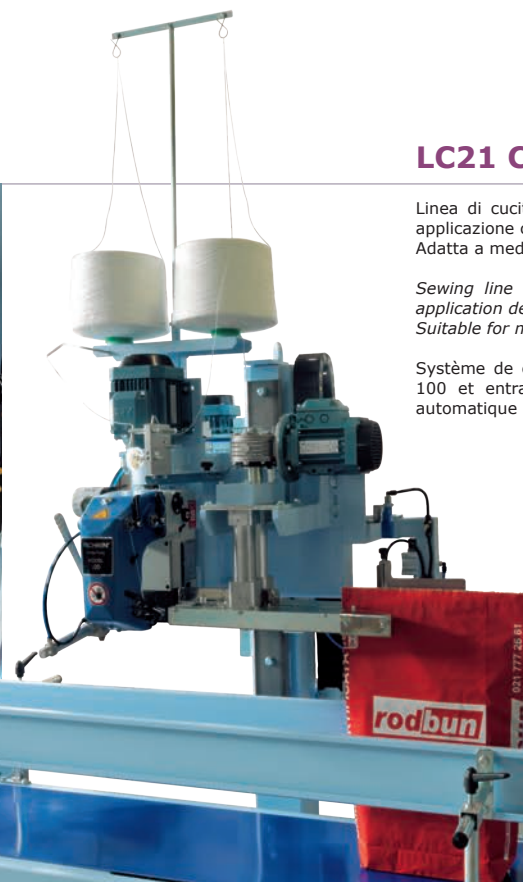
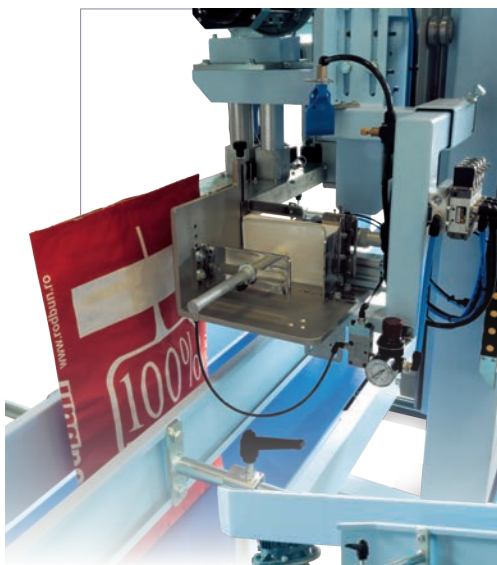

Linea peso lordo - Open mouth gross packer - Ligne de pesage-ensachage à pesées brutes

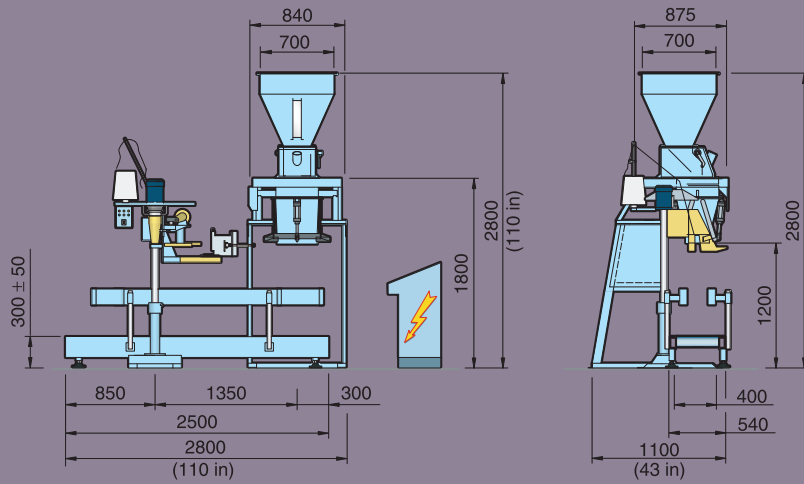

Linea peso netto - Open mouth net packer - Ligne de pesage-ensachage à pesées nettes

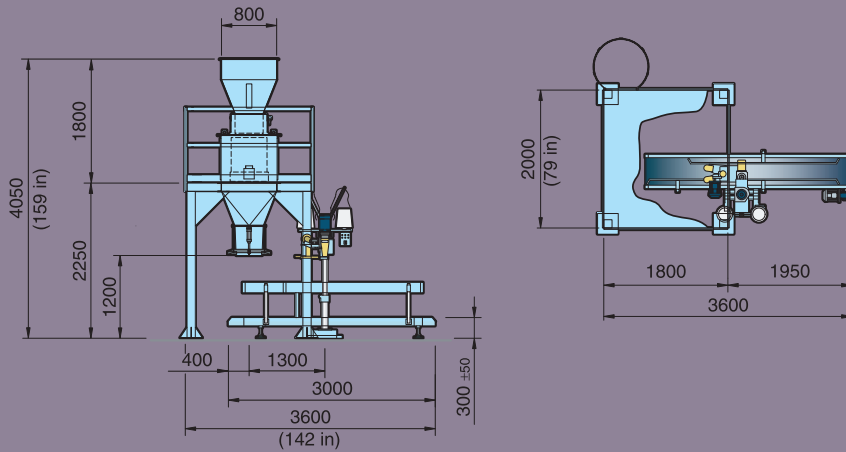

**Technipes**

WEIGHING  
BAGGING  
PALLETISING  
HANDLING



TECHNIPES s.r.l.  
47822 Santarcangelo di Romagna (RN) Italy - via del Gelso, 12 - Phone +39 0541.624.970 - Fax +39 0541.625.902  
E-mail: [technipes@technipes.com](mailto:technipes@technipes.com) - Web: [www.technipes.com](http://www.technipes.com)